

ITEM	QTY.	PART NO.	DESCRIPTION	SOURCE
1	2		SQUARE TUBE, ALUM., 7'-0" X 1.5" X 1.5" X 0.125"	ONLINEMETALS.COM
2	1	A3211218-6061	STRUCTURAL ANGLE, ALUM., 2'-0" X 2" X 1.5" X 0.125"	METALSDEPOT.COM
3	1	A332316	STRUCTURAL ANGLE, ALUM., 2'-0" X 3" X 2" X 0.188"	METALSDEPOT.COM
4	1		SQUARE TUBE, ALUM., 1'-0" X 1.25" X 1.25" X 0.125"	ONLINEMETALS.COM
5	12	DXE-RSB-105000	RESIN SUPPORT BLOCK SADDLE CLAMP, 1/2"	DXENGINEERING.COM
6	6		TUBING, ALUM., 6063-T832, 6'-0" X 1/2" OD	TEXASTOWERS.COM
7	6		TUBING, ALUM., 6063-T832, 6'-0" X 3/8" OD	TEXASTOWERS.COM
8	2	DXE-CAVS-2P	V-BOLT SADDLE CLAMP, SS	DXENGINEERING.COM
9	1	1131	SO-239, CABLE MOUNT	THEWIREMAN.COM
10	24	92196A546	SOCKET HEAD CAP SCREW, 1/4-20 X 1-1/2", SS	MCMMASTER.COM
11	24	92186A552	HEX HEAD CAP SCREW, 1/4-20 X 2-1/2", SS	MCMMASTER.COM
12	24	92196A535	SOCKET CAP SCREW, 1/4-20 X 3/8", SS	MCMMASTER.COM
13	76	98437A110	LOCKWASHER, 1/4", SS	MCMMASTER.COM
14	28	91525A117	WASHER, FLAT, 1/4", 1/2" OD, SS	MCMMASTER.COM
15	4	91772A151	PAN HEAD MACHINE SCREW, #6 X 3/4", SS	MCMMASTER.COM
16	12	90822A146	SELF-DRILLING SCREW, HEX HEAD, #6 X 3/8", SS	MCMMASTER.COM
17	2	7113K815	RING TERMINAL, #6, 16-14 AWG	MCMMASTER.COM
18	4	98437A104	LOCKWASHER, #6, SS	MCMMASTER.COM
19	4	91841A007	MACHINE SCREW HEX NUT, 6-32, SS	MCMMASTER.COM
20	8	91841A029	MACHINE SCREW HEX NUT, 1/4-20, SS	MCMMASTER.COM
21	1	8543K49	FIBERGLASS ROD, 6-1/2" X 3/8" OD	MCMMASTER.COM
22	4	92186A550	SOCKET CAP SCREW, 1/4-20 X 2", SS	MCMMASTER.COM
23	1	106	COAX, 50 OHM, CQ "SUPER 8"	THEWIREMAN.COM

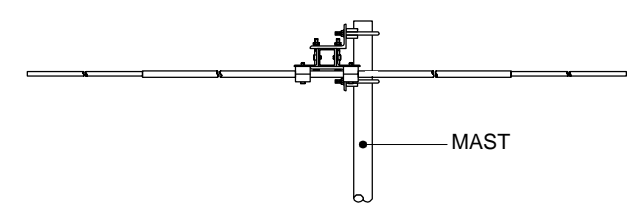

KG4JJH

**6M 6-ELEMENT OWA YAGI
ASSEMBLY**

SIZE B	DESIGN A. BAKER	DWG NO	REV 0
SCALE 1/16 : 1	SHEET 1 OF 3		

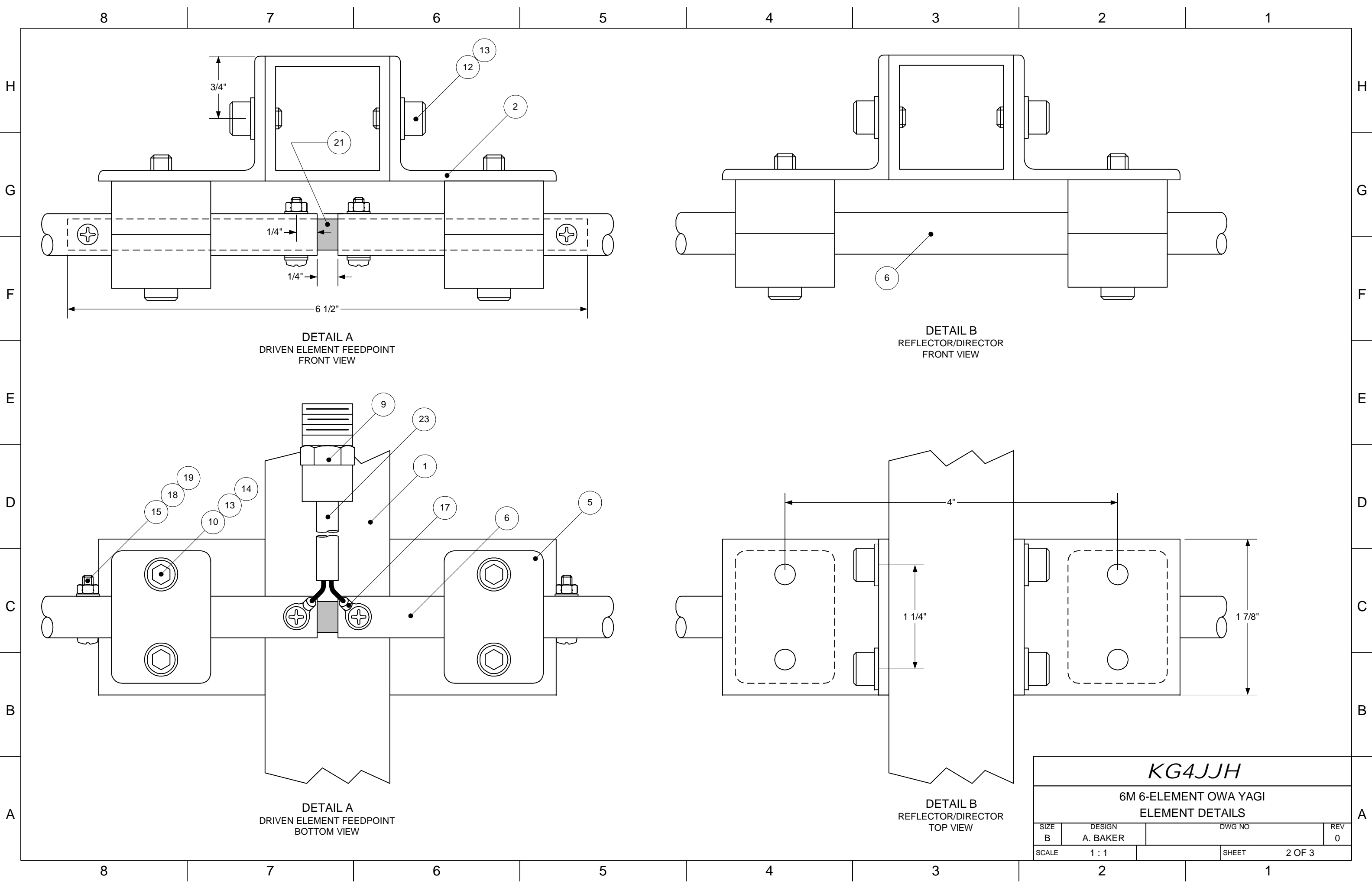

DETAIL A
DRIVEN ELEMENT FEEDPOINT
FRONT VIEW

DETAIL B
REFLECTOR/DIRECTOR
FRONT VIEW

DETAIL A
DRIVEN ELEMENT FEEDPOINT
BOTTOM VIEW

DETAIL B
REFLECTOR/DIRECTOR
TOP VIEW

KG4JJH			
6M 6-ELEMENT OWA YAGI ELEMENT DETAILS			
SIZE B	DESIGN A. BAKER	DWG NO	REV 0
SCALE 1 : 1	SHEET 2 OF 3		

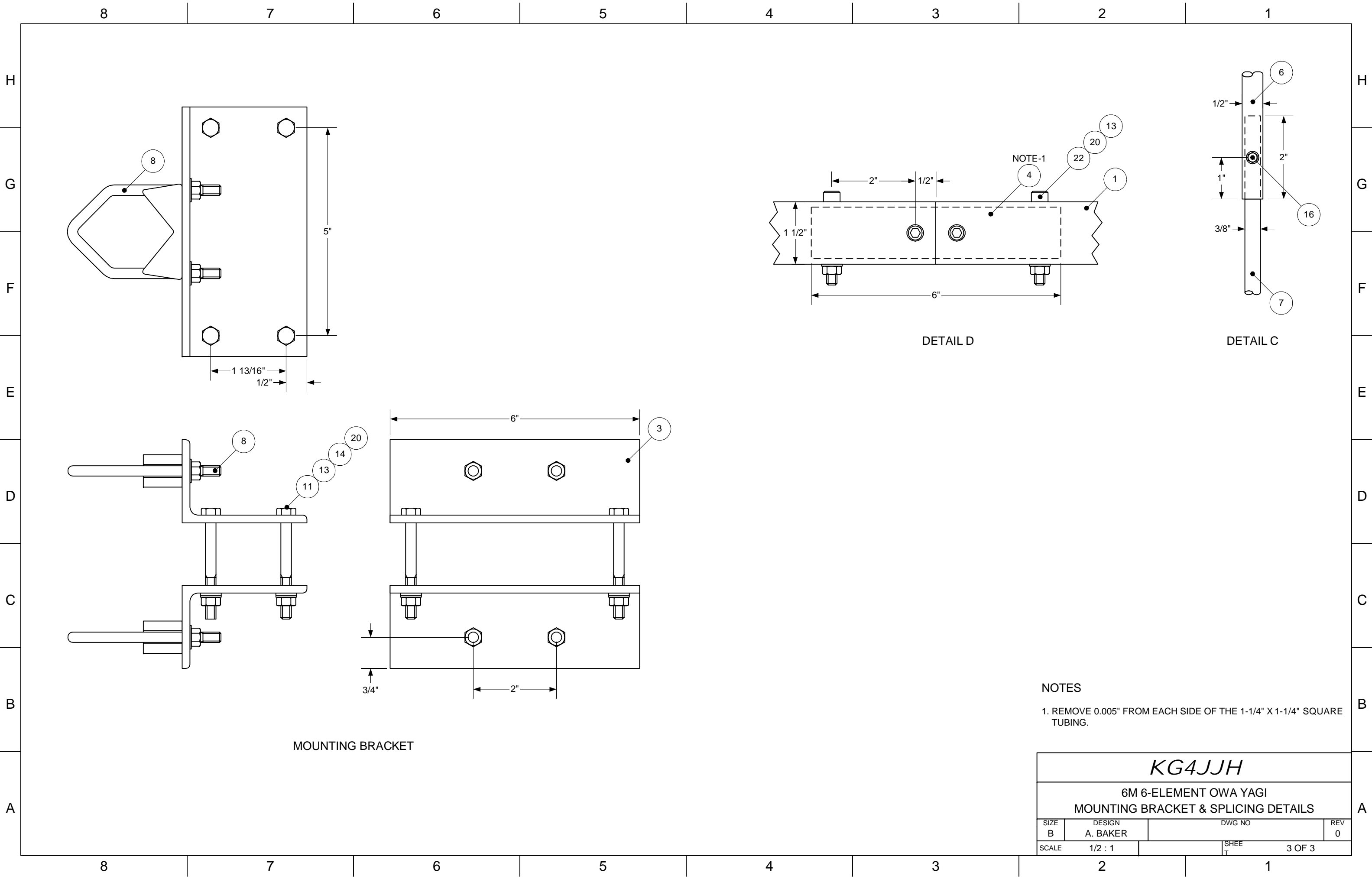

NOTES
 1. REMOVE 0.005" FROM EACH SIDE OF THE 1-1/4" X 1-1/4" SQUARE TUBING.

KG4JJH			
6M 6-ELEMENT OWA YAGI MOUNTING BRACKET & SPLICING DETAILS			
SIZE B	DESIGN A. BAKER	DWG NO	REV 0
SCALE 1/2 : 1	SHEET 3 OF 3		