

6M MOXON RECTANGLE

DIMENSION	H-POL (NOTE-1)	V-POL (NOTE-2)
A	84-1/2"	80-3/16"
B	11-1/4"	10-9/16"
C	3-13/16"	3-3/4"
D	16-1/8"	15-1/2"
E	31-3/16"	29-13/16"

NOTES

- H-POL: 50.5 MHZ RESONANT FREQUENCY COVERS 50.0 TO 51.0 MHZ (CW, SSB, & DIGITAL MODES) WITH MAX. SWR OF 1.3:1.
- V-POL: 52.9 MHZ RESONANT FREQUENCY COVERS 52.0 TO 54.0 MHZ (FM MODE) WITH MAX. SWR OF 1.6:1.
- SELECT VERSION AND CUT MATERIAL PER SCHEDULE BELOW:

MATERIAL CUTTING SCHEDULE					
ITEM	QTY	MATERIAL	OD SIZE	H-POL	V-POL
A ₀	1	FIBERGLASS	1/2"	10"	10"
A ₁	2	ALUM. TUBE	5/8"	26-3/8"	26-3/8"
A ₂	4	ALUM. TUBE	1/2"	17-3/4"	15-5/8"
A ₃	1	ALUM. TUBE	5/8"	53"	53"
A ₄	4	ALUM. ROD	3/8"	8"	8"
B ₁	2	ALUM. TUBE	1/2"	10-1/4"	9-9/16"
C ₁	2	FIBERGLASS	3/8"	10"	10"
D ₁	2	ALUM. TUBE	1/2"	15-1/8"	14-1/2"
BOOM	1	ALUM. TUBE	7/8"	34"	32-3/4"
BOOM	1	ALUM. TUBE	1"	34"	32-3/4"

DESIGN: A.W. BAKER 06/23/03
 TESTED: A.W. BAKER 07/04/03



**MOXON RECTANGLE
 6 METER BEAM
 ASSEMBLY**

SCALE: 1/8:1

SHEET 1 OF 7

REV. 0

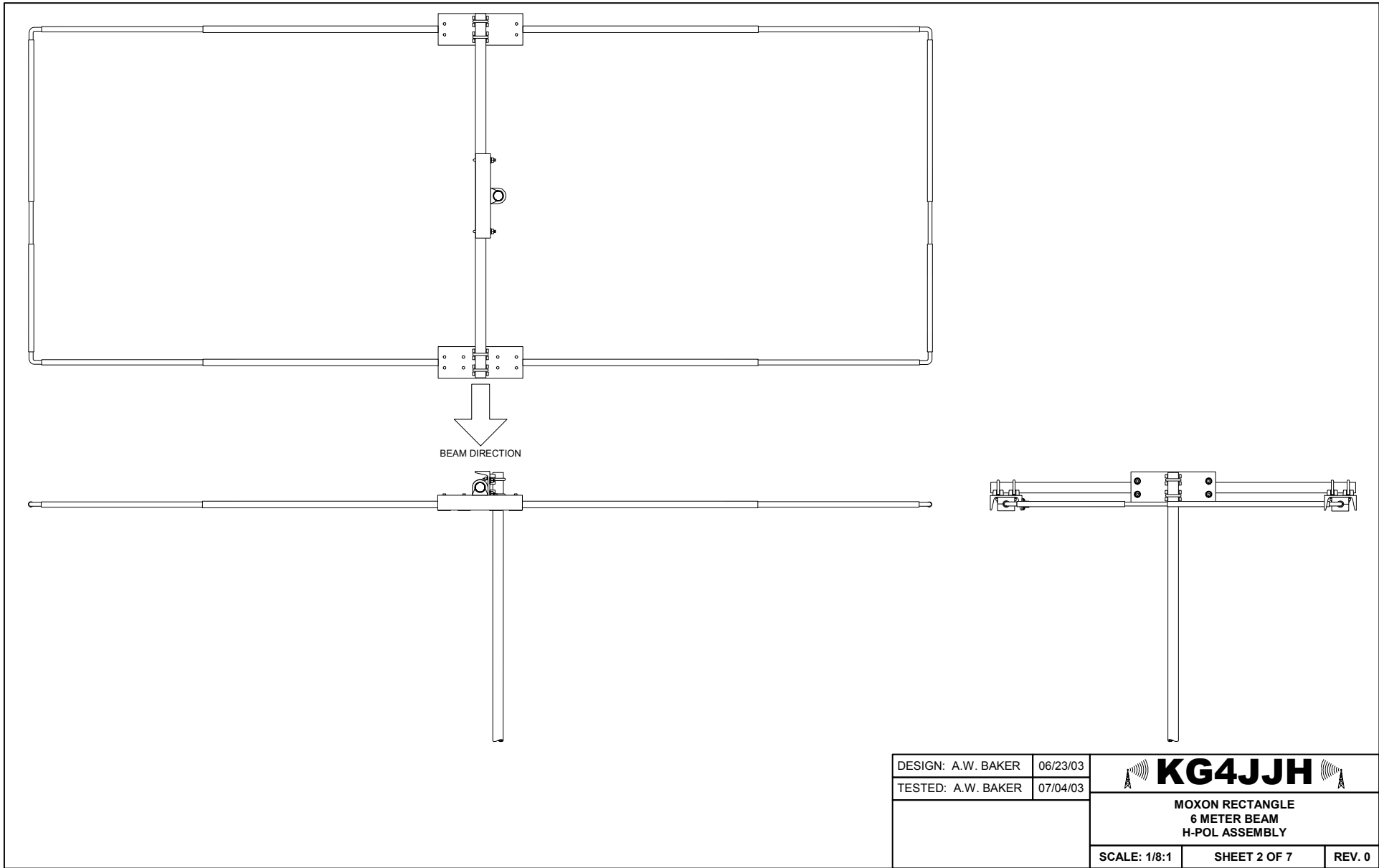

DESIGN: A.W. BAKER	06/23/03
TESTED: A.W. BAKER	07/04/03



KG4JJH



MOXON RECTANGLE
 6 METER BEAM
 H-POL ASSEMBLY

SCALE: 1/8:1

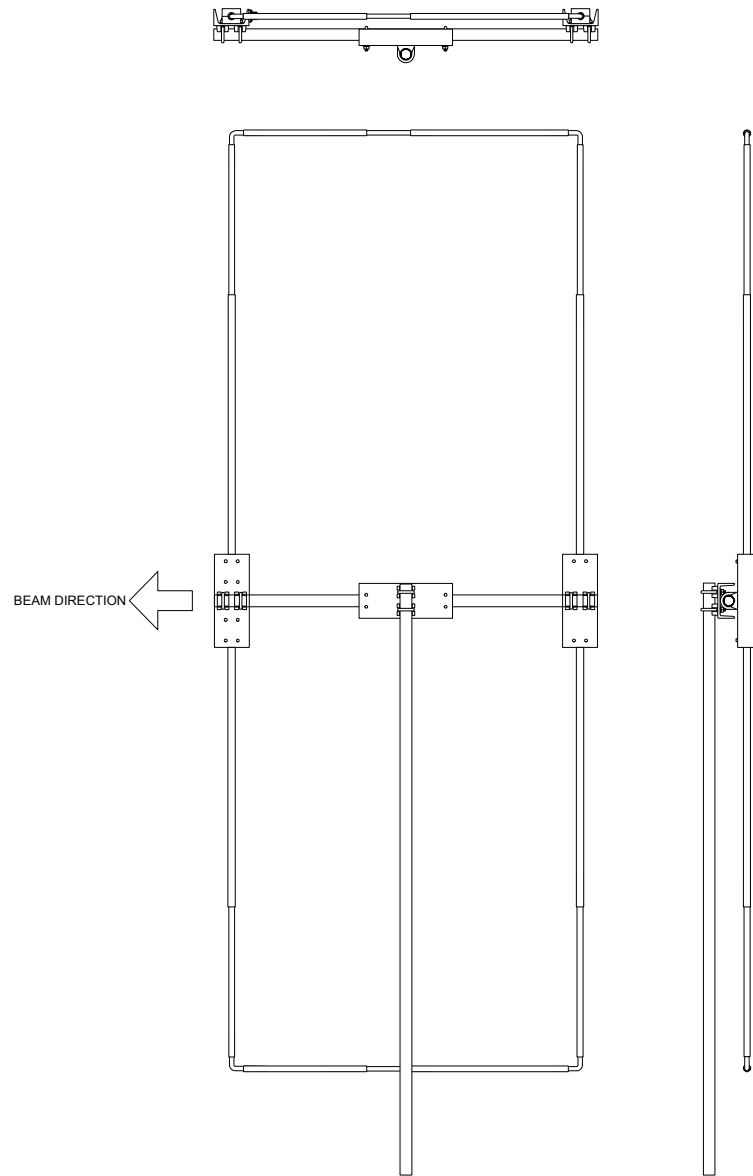
SHEET 2 OF 7

REV. 0



DESIGN: A.W. BAKER	06/23/03	 KG4JJH
TESTED: A.W. BAKER	07/04/03	
		MOXON RECTANGLE 6 METER BEAM V-POL ASSEMBLY
		SCALE: 1/10:1
		SHEET 3 OF 7
		REV. 0

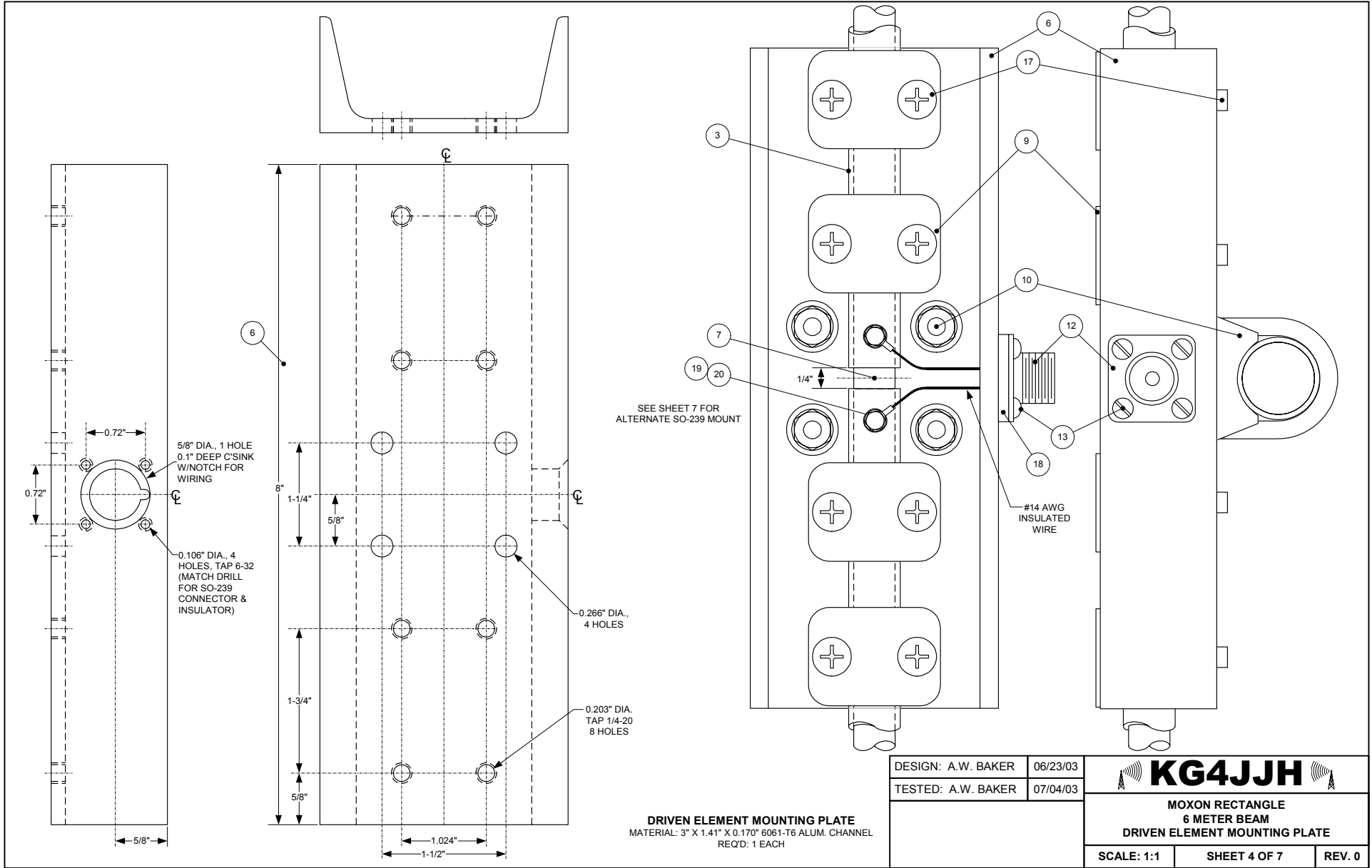

5/8" DIA., 1 HOLE
0.1" DEEP C'SINK
W/NOTCH FOR
WIRING

0.106" DIA., 4
HOLES, TAP 6-32
(MATCH DRILL
FOR SO-239
CONNECTOR &
INSULATOR)

SEE SHEET 7 FOR
ALTERNATE SO-239 MOUNT

#14 AWG
INSULATED
WIRE

DRIVEN ELEMENT MOUNTING PLATE
MATERIAL: 3" X 1.41" X 0.170" 6061-T6 ALUM. CHANNEL
REQ'D: 1 EACH

DESIGN: A.W. BAKER	06/23/03
TESTED: A.W. BAKER	07/04/03

KG4JJH

**MOXON RECTANGLE
6 METER BEAM
DRIVEN ELEMENT MOUNTING PLATE**

SCALE: 1:1	SHEET 4 OF 7	REV. 0
------------	--------------	--------

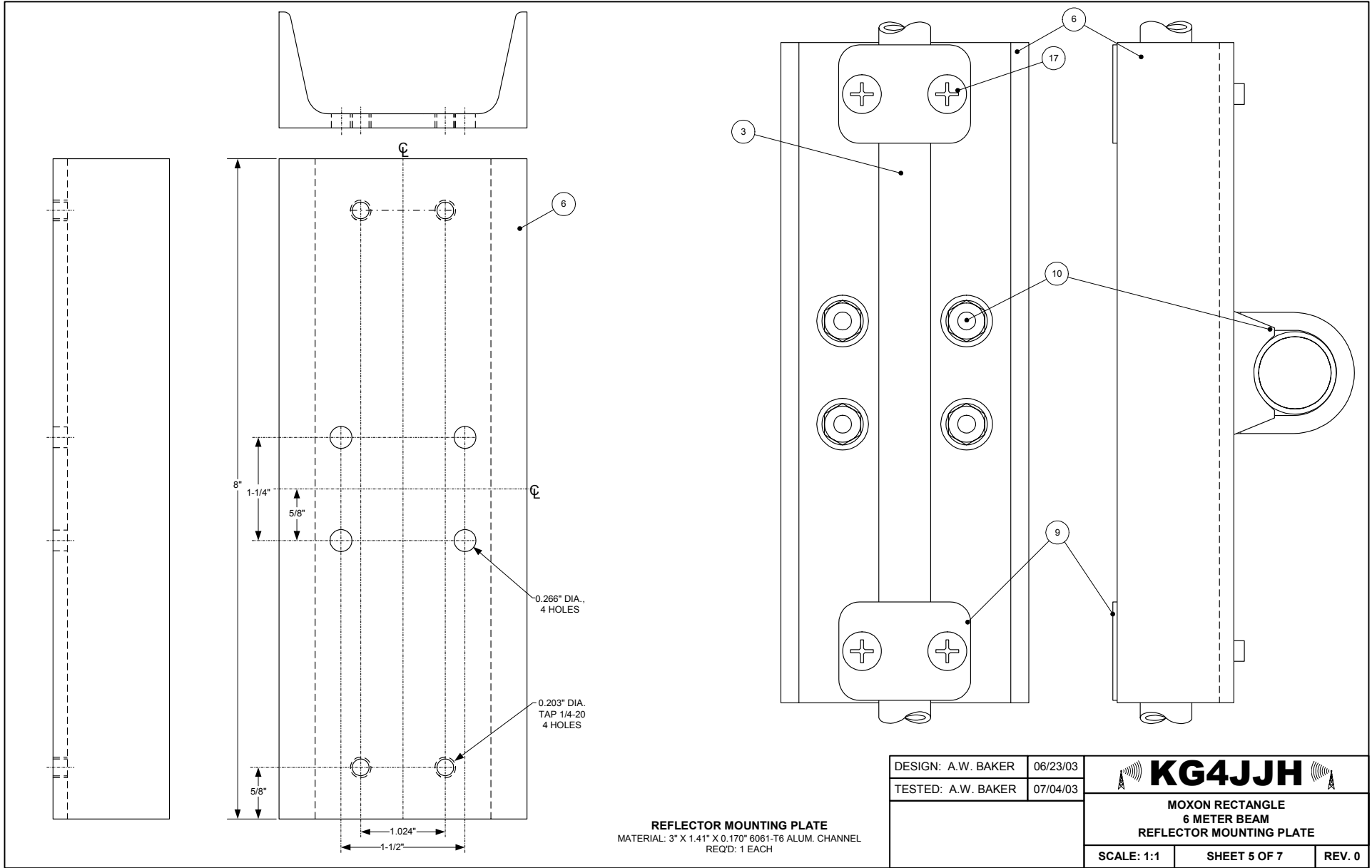

REFLECTOR MOUNTING PLATE
 MATERIAL: 3" X 1.41" X 0.170" 6061-T6 ALUM. CHANNEL
 REQ'D: 1 EACH

DESIGN: A.W. BAKER	06/23/03
TESTED: A.W. BAKER	07/04/03

MOXON RECTANGLE 6 METER BEAM REFLECTOR MOUNTING PLATE		
SCALE: 1:1	SHEET 5 OF 7	REV. 0

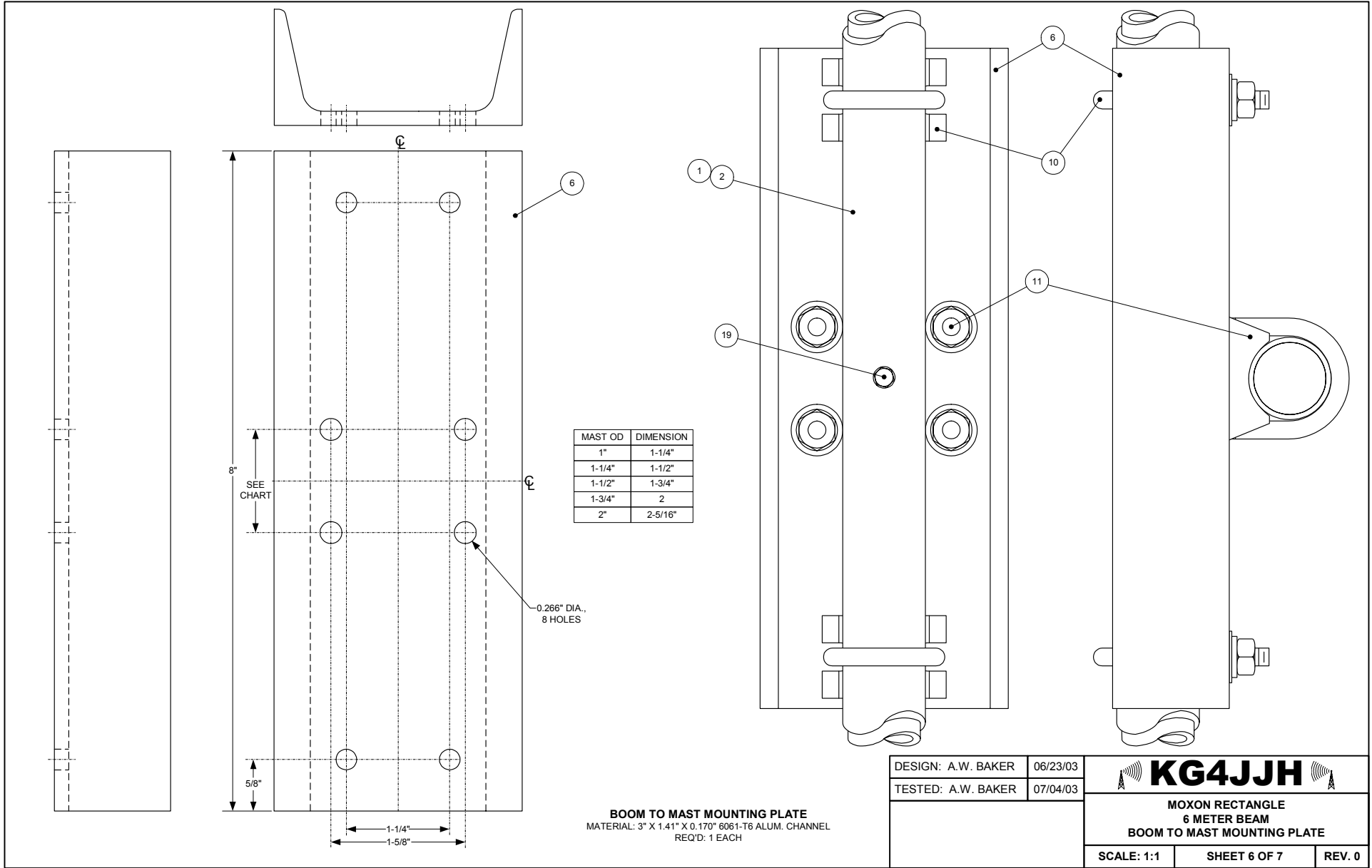

MAST OD	DIMENSION
1"	1-1/4"
1-1/4"	1-1/2"
1-1/2"	1-3/4"
1-3/4"	2
2"	2-5/16"

BOOM TO MAST MOUNTING PLATE
 MATERIAL: 3" X 1.41" X 0.170" 6061-T6 ALUM. CHANNEL
 REQ'D: 1 EACH

DESIGN: A.W. BAKER 06/23/03
 TESTED: A.W. BAKER 07/04/03

KG4JJH

**MOXON RECTANGLE
 6 METER BEAM
 BOOM TO MAST MOUNTING PLATE**

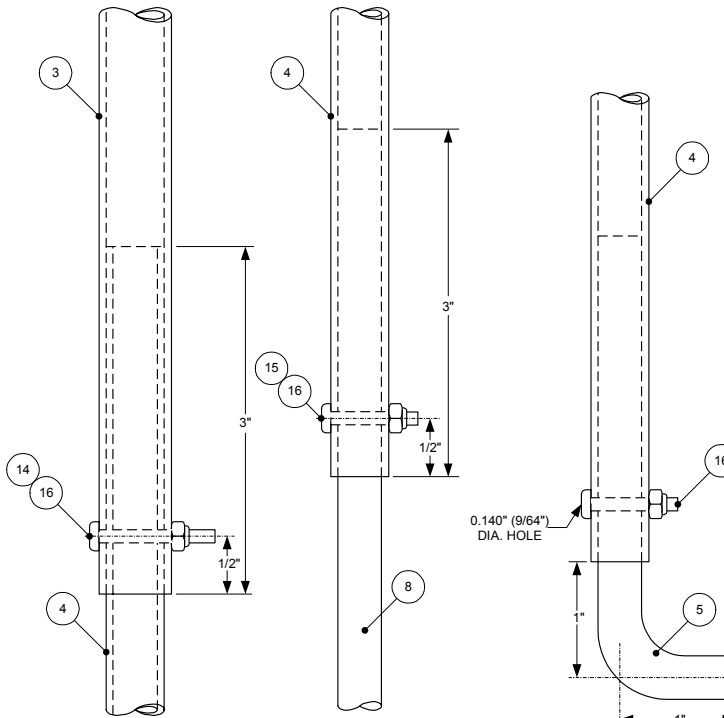

TYPICAL TUBING FASTENERS

MATERIALS LIST					
ITEM	QTY	DESCRIPTION	PRICE	SOURCE-1	SOURCE-2
1	3 FT.	6063-T832 DRAWN ALUMINUM ROUND TUBING, 1.000"OD, 0.884"ID	\$1.20/FT.	WWW.TEXASTOWERS.COM	
2	3 FT.	6063-T832 DRAWN ALUMINUM ROUND TUBING, 0.875"OD, 0.759"ID	\$1.10/FT.	WWW.TEXASTOWERS.COM	
3	9 FT.	6063-T832 DRAWN ALUMINUM ROUND TUBING, 0.625"OD, 0.509"ID	\$0.90/FT.	WWW.TEXASTOWERS.COM	
4	11 FT.	6063-T832 DRAWN ALUMINUM ROUND TUBING, 0.500"OD, 0.384"ID	\$0.80/FT.	WWW.TEXASTOWERS.COM	
5	3 FT.	ALUMINUM ROUND ROD, 0.375"OD	\$3.69	HOME DEPOT	LOWES
6	2 FT.	6061-T6 ALUMINUM STRUCTURAL CHANNEL, 3" X 1.41" X 0.170"	\$6.79/FT.	WWW.METALSDEPOT.COM	
7	10 IN.	SOLID FIBERGLASS ROUND ROD, 1/2" OD	\$1.00/FT.	WWW.MGS4U.COM	WWW.MCMMASTER.COM
8	20 IN.	SOLID FIBERGLASS ROUND ROD, 3/8" OD	\$0.83/FT.	WWW.MGS4U.COM	WWW.MCMMASTER.COM
9	6	RADIO SUPPORT BLOCK, 5/8", DXE-RSB-IO6250	\$2.59	WWW.DXENGINEERING.COM	WWW.HYDACUSA.COM/ VALVES/HTPLCLAMPS.HTM
10	6	BOOM SADDLE CLAMP, STAINLESS STEEL, 1" OD, DXE-SAD-100	\$4.49	WWW.DXENGINEERING.COM	
11	2	MAST SADDLE CLAMP, STAINLESS STEEL, SEE TEXT	\$5.00	WWW.DXENGINEERING.COM	
12	1	CONNECTOR, CHASSIS MOUNT, SO-239	\$2.99	RADIO SHACK	
13	4	ROUND HEAD MACHINE SCREW, NYLON, 6-32NC X 1/2"	\$0.15	LOWES	WWW.MCMMASTER.COM
14	8	PAN HEAD MACHINE SCREW, STAINLESS STEEL, 6-32NC X 1"	\$0.16	ACE HARDWARE	WWW.MCMMASTER.COM
15	12	PAN HEAD MACHINE SCREW, STAINLESS STEEL, 6-32NC X 3/4"	\$0.15	ACE HARDWARE	WWW.MCMMASTER.COM
16	20	HEX STOP NUT, STAINLESS STEEL, 6-32NC	\$0.15	ACE HARDWARE	WWW.MCMMASTER.COM
17	12	ROUND HEAD MACHINE SCREW, STAINLESS STEEL, 1/4-20NC X 1-1/4"	\$0.23	ACE HARDWARE	WWW.MCMMASTER.COM
18	1	CAP, PVC, 1-1/2", SCHEDULE 40	\$0.50	HOME DEPOT	LOWES
19	2	HEX HEAD THREAD CUTTING SCREW, STAINLESS STEEL, #6 X 1/2"	\$0.10	ACE HARDWARE	WWW.MCMMASTER.COM
20	2	RING TERMINAL, #6	\$0.05	RADIO SHACK	LOWES

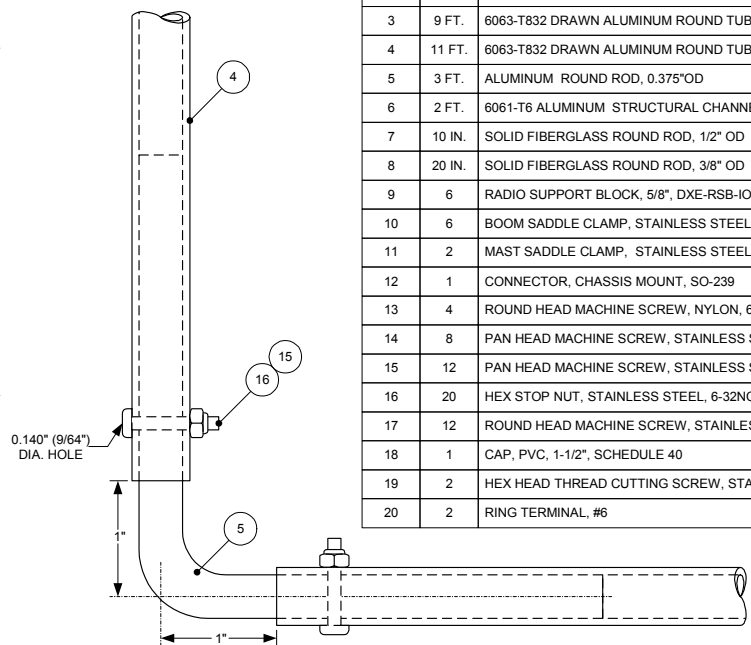

CORNERS
MATERIAL: 3/8" ALUM. ROD, 8" LONG
BEND 90 DEGREES (SEE TEXT)
REQ'D: 4 EACH

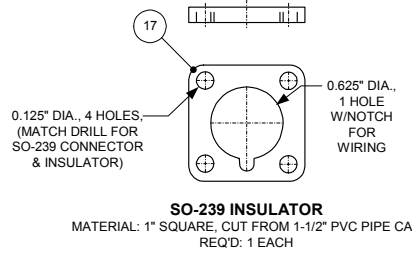

SO-239 INSULATOR

MATERIAL: 1" SQUARE, CUT FROM 1-1/2" PVC PIPE CAP
REQ'D: 1 EACH

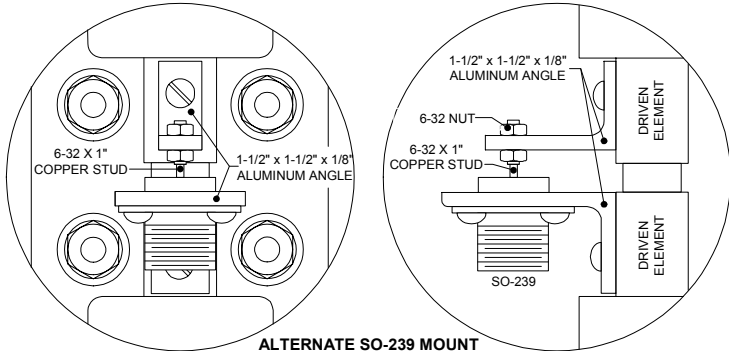

ALTERNATE SO-239 MOUNT
(SEE TEXT)

DESIGN: A.W. BAKER	06/23/03
TESTED: A.W. BAKER	07/04/03
A	BM ITEM 10 QTY TO 6
REV	DESCRIPTION
	DATE

MOXON RECTANGLE
6 METER BEAM
MISC. DETAILS & MATERIALS LIST

SCALE: 1:1	SHEET 7 OF 7	REV. A
------------	--------------	--------